



MAFFS PUMPS
P V T L T D



- MANUFACTURE
- SERVICES PROVIDER
- EXPORTER
- PROJECT SUPPLIER

All types of Industrial Pumps
and all types of pumps spares
etc.



MAFFS PUMPS
P V T L T D

Pump Specification:



Cross Section View

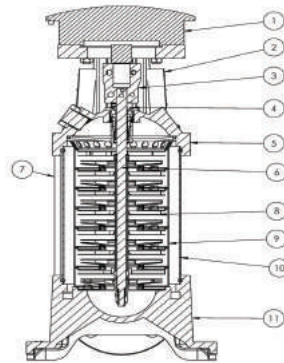

BOM of Pumps

MAIN COMPONENT		
No.	Description	Material
1	Motor	
2	Coupling Cover	SS304
3	Coupling	Cast Iron
4	Mechanical Seal	Carbon/TC/Viton
5	Deffuser	SS304
6	Uper Casting	Cast Iron
7	Pump Shaft	SS304
8	Tention Bar	SS304
9	Impeller	SS304
10	Deffuser Assembly	SS304
11	Outer Sleeve	SS304
12	Base	Cast Iron

General Specification Detail Dwg:-

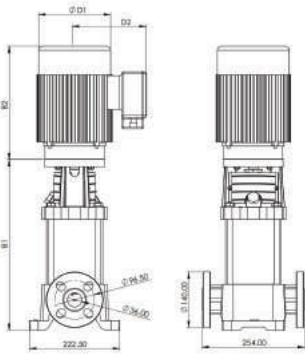

MODEL	SIZE(mm)				
	B1	B2	B1+B2	D1	D2
KP2-9	404.50	271.50	676.00	162.00	145.50
KP2-11	440.50	271.50	712.00	162.00	145.50
KP2-13	476.50	276.60	753.10	182.80	153.60
KP2-15	512.50	276.60	789.10	182.80	153.60
KP2-18	566.50	276.60	843.10	182.80	153.60
KP2-22	638.50	276.60	915.10	182.80	153.60
KP4-12	566.50	276.60	843.10	182.80	153.60
KP4-16	674.50	308.00	982.50	195.00	176.65
KP4-19	755.50	308.00	1063.50	195.00	176.65

Eco Type:-

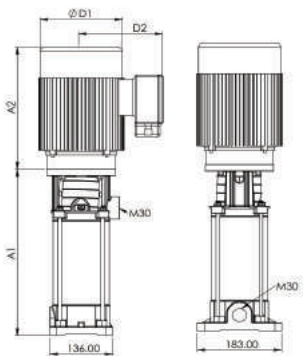

MODEL	SIZE(mm)				
	A1	A2	A1+A2	D1	D2
KP2-9	389.45	271.50	660.95	162.00	145.50
KP2-11	425.45	271.50	696.95	162.00	145.50
KP2-13	461.45	276.60	738.05	182.80	153.60
KP2-15	497.45	276.60	774.05	182.80	153.60
KP2-18	561.45	276.60	838.05	182.80	153.60
KP2-22	623.45	276.60	900.05	182.80	153.60



Our Products:-

2 Series- Flange Type :-



KP2-9



KP2-11



KP2-13



KP2-15



KP2-18



KP2-22

2 Series- Eco Type :-



KP2-9



KP2-11



KP2-13



KP2-15



KP2-18



KP2-22

4 Series- Flange Type :-



KP4-12



KP4-16



KP4-19



KP4-22



Pumps Series - KP2-9 Technical Data:-

Flow rate : 0-89.4 L/m
 Flow height: 84.3 m
 Voltage : 214-223v
 Frequency : 50 Hz
 PF : 0.98
 Material :Stainless steel

Pump Testing Data 2-9(1.5HP)							
Frequency-50HZ		PF-0.93					
SR NO	Voltage (V)	Current (A)	Input Power (W)	Output Power (W)	Flow rate (liter/min)	Flow Height (m)	Overall Efficiency%
1	223	5.2	1.1596	0.000	0	84.3	0.00
2	220	6.65	1.463	0.400	34.8	70.3	27.32
3	219.8	6.97	1.532006	0.466	45	63.4	30.43
4	217.8	7	1.5246	0.487	53.3	55.9	31.93
5	217.8	7	1.5246	0.465	62.9	45.2	30.47
6	217.8	7	1.5246	0.399	71.8	34	26.16
7	218.6	6.8	1.48648	0.330	78.2	25.8	22.18
8	215	6.5	1.3975	0.244	82.8	18	17.43
9	214	6.4	1.3696	0.188	85.2	13.5	13.72
10	214	6.32	1.35248	0.145	86.9	10.2	10.71
11	217	6.3	1.3671	0.1023	89.4	7	7.48

Application:-

- > Water supply System
- > Ro Plant
- > Industrial washing system
- > STV Plant
- > Boiler feed system
- > Heavy machinery like VMC, Wire cut.



Model-KP2-9

Performance Chart :-

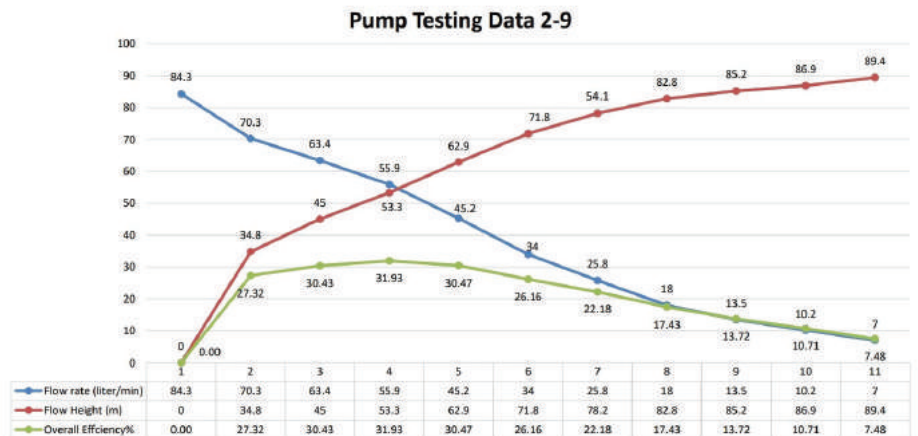
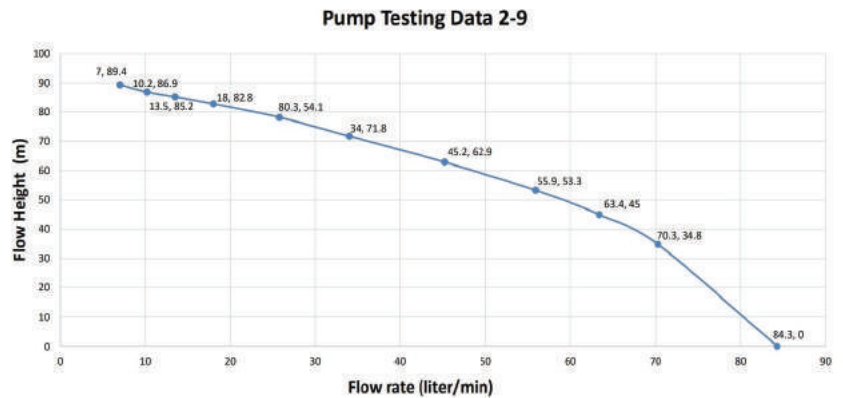



MAFFS PUMPS
P V T L T D

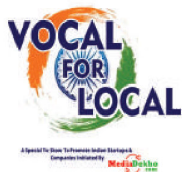

Factory Address:-

**134, Industrial Estate, Sangli - 416416 (M.S. - India)
Contact 9820568022**

**Regd Office 303, Badhra Apartment, Western Park,
Misquita Wadi, Western Express Highway No. 8,
Mira Road (East) Dist. Thane 401107, India.**

Contact No 9820568098

E-Mail : sales@maffspumps.com

www.maffspumps.com